

PEARSON
Prentice
Hall

Engineering Mechanics: Statics Tenth Edition

CHAPTER

STRUCTURAL ANALYSIS

UMBC

•College of Engineering •Department of Mechanical Engineering

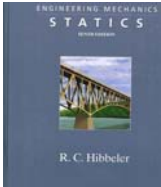

by
Dr. Ibrahim A. Assakkaf
SPRING 2007
ENES 110 – Statics
Department of Mechanical Engineering
University of Maryland, Baltimore County

6a

UMBC Chapter 6a. STRUCTURAL ANALYSIS Slide No. 1

Trusses – Methods of Joints

Lecture's Objectives:

Students will be able to:

- Define a simple truss.
- Determine the forces in members of a simple truss.
- Identify zero-force members.

In-Class Activities:

- Reading quiz
- Applications
- Simple truss
- Methods of joints
- Zero-force members
- Concept quiz
- Group problem solving
- Attention quiz

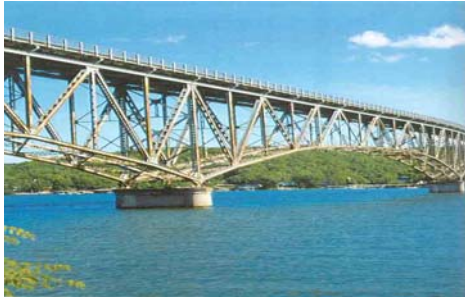

ENES110 ©Assakkaf_SP07

Reading Quiz

1. One of the assumptions used when analyzing a simple truss is that the members are joined together by _____.
A) welding B) bolting C) riveting
D) smooth pins E) super glue
2. In the method of joints, typically _____ equations of equilibrium are applied at every joint.
A) two B) three
C) four D) six

Applications



Trusses are commonly used to support a roof.

For a given truss geometry and load, how can we determine the forces in the truss members and select their sizes?



A more challenging question is that for a given load, how can we design the trusses' geometry to minimize cost?

Applications (cont'd)



Trusses are also used in a variety of structures like cranes and the frames of aircraft or space stations.

How can we design a light weight structure that will meet load, safety, and cost specifications?

ENES110 ©AsstProf_SP07

Defining a Simple Truss (Section 6.1)

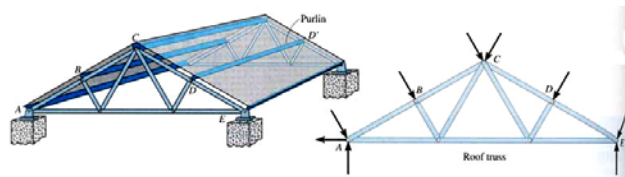

A truss is a structure composed of slender members joined together at their end points.

If a truss, along with the imposed load, lies in a single plane (as shown at the top right), then it is called a planar truss.

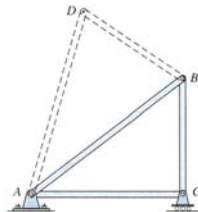

A simple truss is a planar truss which begins with a triangular element and can be expanded by adding two members and a joint. For these trusses, the number of members (M) and the number of joints (J) are related by the equation $M = 2J - 3$.

ENES110 ©AsstProf_SP07

Analysis and Design Assumptions

When designing both the member and the joints of a truss, first it is necessary to determine the forces in each truss member. This is called the force analysis of a truss. When doing this, two assumptions are made:

1. All loads are applied at the joints. The weight of the truss members is often neglected as the weight is usually small as compared to the forces supported by the members.
2. The members are joined together by smooth pins. This assumption is satisfied in most practical cases where the joints are formed by bolting or welding.

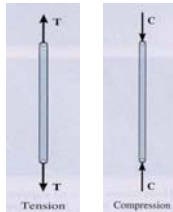

With these two assumptions, the members act as two-force members. They are loaded in either tension or compression. Often compressive members are made thicker to prevent buckling.

ENES110 ©Asst.Kaf_Sp07

The Method of Joints (Section 6.2)

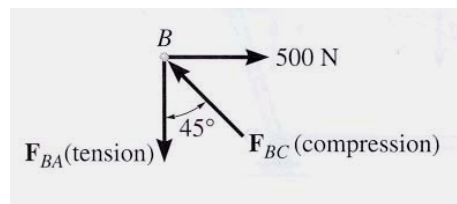
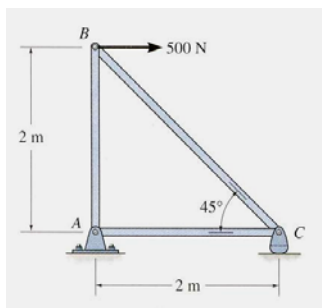

In this method of solving for the forces in truss members, the equilibrium of a joint (pin) is considered. All forces acting at the joint are shown in a FBD. This includes all external forces (including support reactions) as well as the forces acting in the members. Equations of equilibrium ($\sum F_x = 0$ and $\sum F_y = 0$) are used to solve for the unknown forces acting at the joints.

ENES110 ©Asst.Kaf_Sp07

Steps for Analysis

1. If the support reactions are not given, draw a FBD of the entire truss and determine all the support reactions using the equations of equilibrium.
2. Draw the free-body diagram of a joint with one or two unknowns. Assume that all unknown member forces act in tension (pulling the pin) unless you can determine by inspection that the forces are compression loads.
3. Apply the scalar equations of equilibrium, $\sum F_x = 0$ and $\sum F_y = 0$, to determine the unknown(s). If the answer is positive, then the assumed direction (tension) is correct, otherwise it is in the opposite direction (compression).
4. Repeat steps 2 and 3 at each joint in succession until all the required forces are determined.

ENES110 ©Asst.Kaf_SPO7

Example 1

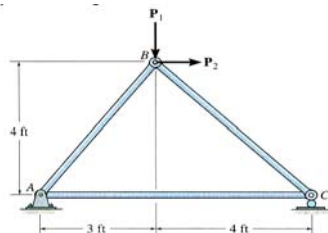

Given: $P_1 = 200 \text{ lb}$, $P_2 = 500 \text{ lb}$

Find: The forces in each member of the truss.

Plan: First analyze pin B and then pin C

$$\begin{aligned}
 &+ \rightarrow \sum F_x = 500 + F_{BC} \cos 45^\circ - (3/5) F_{BA} = 0 \\
 &+ \uparrow \sum F_y = -200 - F_{BC} \sin 45^\circ - (4/5) F_{BA} = 0 \\
 &\underline{F_{BA} = 214 \text{ lb (T)}} \quad \text{and} \quad \underline{F_{BC} = -525.3 \text{ lb (C)}}
 \end{aligned}$$

FBD of pin B

$$\begin{aligned}
 &+ \rightarrow \sum F_x = -F_{CA} + 525.3 \cos 45^\circ = 0 \\
 &\underline{F_{CA} = 371 \text{ (T)}}
 \end{aligned}$$

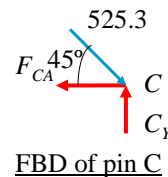

FBD of pin C

ENES110 ©Asst.Kaf_SPO7

Zero-Force Members (Section 6.3)

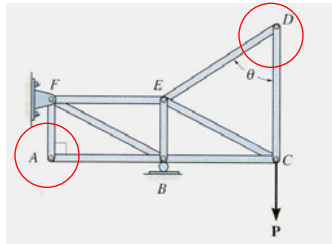

If a joint has only two non-collinear members and there is no external load or support reaction at that joint, then those two members are zero-force members. In this example members DE , CD , AF , and AB are zero force members.

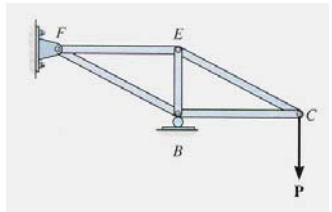

You can easily prove these results by applying the equations of equilibrium to joints D and A .

Zero-force members can be removed (as shown in the figure) when analyzing the truss.

ENES110 ©Asst.Kaf_Sp07

Zero-Force Members (cont'd)

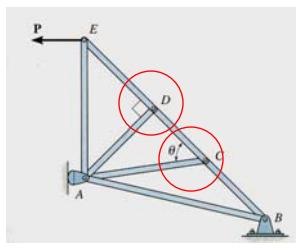

If three members form a truss joint for which two of the members are collinear and there is no external load or reaction at that joint, then the third non-collinear member is a zero force member.

Again, this can easily be proven. One can also remove the zero-force member, as shown, on the left, for analyzing the truss further.

Please note that zero-force members are used to increase stability and rigidity of the truss, and to provide support for various different loading conditions.

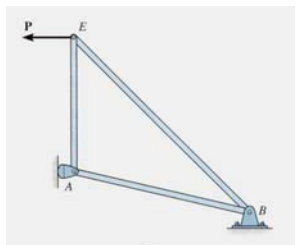

ENES110 ©Asst.Kaf_Sp07

Concept Quiz

1. Truss ABC is changed by decreasing its height from h to $0.9h$. Width w and load P are kept the same. Which one of the following statements is true for the revised truss as compared to the original truss?

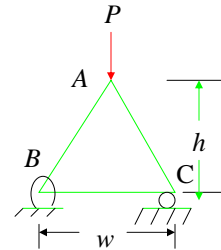

- A) Force in all its members have decreased.
- B) Force in all its members have increased.
- C) Force in all its members have remained the same.
- D) None of the above.

ENES110 ©AsstProf_SP07

Concept Quiz (cont'd)

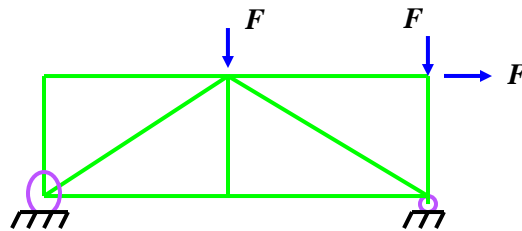

2. For this truss, determine the number of zero-force members.
- A) 0
 - B) 1
 - C) 2
 - D) 3
 - E) 4

ENES110 ©AsstProf_SP07

Example 2

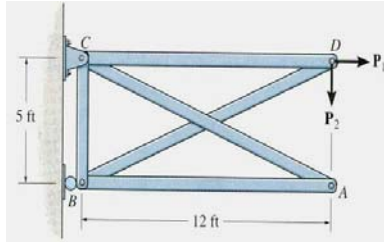

Given: $P_1 = 240$ lb and

$P_2 = 100$ lb

Find: Determine the force in all the truss members (do not forget to mention whether they are in **T** or **C**).

Plan:

- Check if there are any zero-force members.
- Draw FBDs of pins D and B , and then apply EofE at those pins to solve for the unknowns.

Solution:

Members AB and AC are zero-force members.

Example 2 (cont'd)

FBD of pin D

Analyzing pin D :

$$\uparrow + \sum F_y = -100 - (5/13) F_{DB} = 0$$

$$F_{DB} = -260 \text{ lb (C)}$$

$$\rightarrow + \sum F_x = 240 - F_{DC} - (12/13)(-260) = 0$$

$$F_{DC} = 480 \text{ lb (T)}$$

Analyzing pin B :

$$\uparrow + \sum F_y = F_{BC} - (5/13) 260 = 0$$

$$F_{BC} = 100 \text{ lb (T)}$$

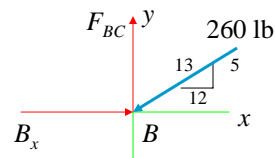
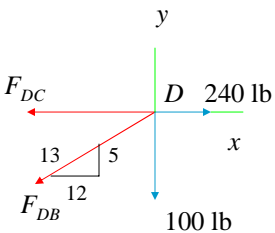

FBD of pin B

Attention Quiz

1. Using this FBD, you find that $F_{BC} = -500$ N.
Member BC must be in _____.

- A) tension B) compression
C) Can not be determined

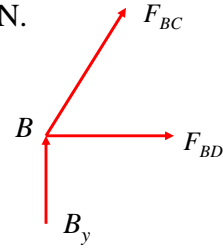

2. For the same magnitude of force to be carried, truss members in compression are generally made _____ as compared to members in tension.

- A) thicker
B) thinner
C) the same size