

PEARSON
Prentice
Hall

Engineering Mechanics: Statics Tenth Edition

CHAPTER

UMBC

EQUILIBRIUM OF A RIGID BODY

•College of Engineering •Department of Mechanical Engineering

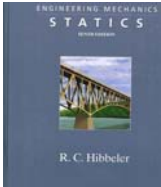

by
Dr. Ibrahim A. Assakkaf
SPRING 2007
ENES 110 – Statics
Department of Mechanical Engineering
University of Maryland, Baltimore County

5a

UMBC Chapter 5a. EQUILIBRIUM OF A RIGID BODY Slide No. 1

Equilibrium of a Rigid Body

Lecture's Objectives:

Students will be able to

- Identify support reactions, and
- Draw a free diagram.

In-Class Activities:

- Reading Quiz
- Applications
- Support reactions
- Free-body diagram
- Concept quiz
- Group problem solving (Ex. 1)
- Attention quiz



ENES110 ©Assakkaf_SP07

Reading Quiz

- If a support prevents only translation of a body, then the support exerts a _____ on the body.
 - couple moment
 - force
 - Both A and B.
 - None of the above
- Internal forces are _____ shown on the free body diagram of a whole body.
 - always
 - often
 - rarely
 - never

Applications

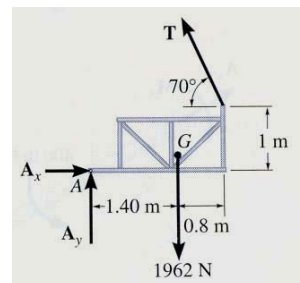
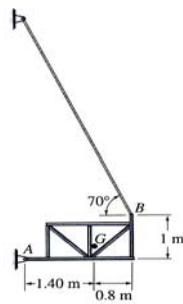

A 200 kg platform is suspended off an oil rig. How do we determine the force reactions at the joints and the forces in the cables?

How are the idealized model and the free body diagram used to do this? Which diagram above is the idealized model?

Applications (cont'd)

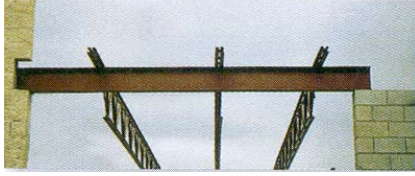

A steel beam is used to support roof joists. How can we determine the support reactions at A & B?

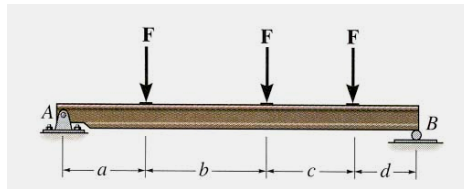

Again, how can we make use of an idealized model and a free body diagram to answer this question?

Conditions for Rigid-Body Equilibrium

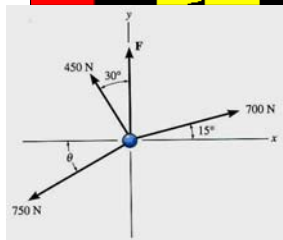

Forces on a particle

In contrast to the forces on a particle, the forces on a rigid-body are not usually concurrent and may cause rotation of the body (due to the moments created by the forces).

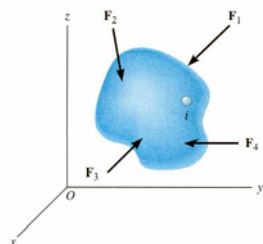

Forces on a rigid body

For a rigid body to be in equilibrium, the net force as well as the net moment about any arbitrary point O must be equal to zero.

$$\sum \mathbf{F} = 0 \text{ and } \sum \mathbf{M}_O = 0$$

The Process of Solving Rigid Body Equilibrium Problems

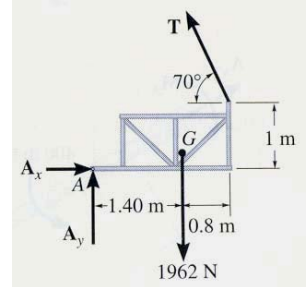
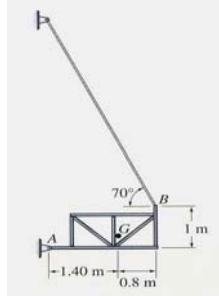

For analyzing an actual physical system, first we need to create an idealized model.

Then we need to draw a free-body diagram showing all the external (active and reactive) forces.

Finally, we need to apply the equations of equilibrium to solve for any unknowns.

ENES110 ©Asst.Kaf_SPO7

Procedure for Drawing a Free Body Diagram (Section 5.2)

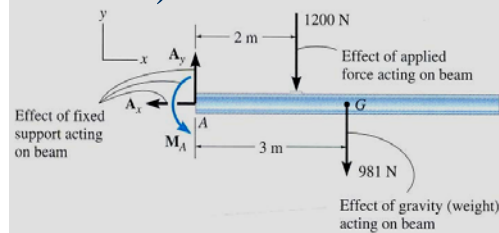
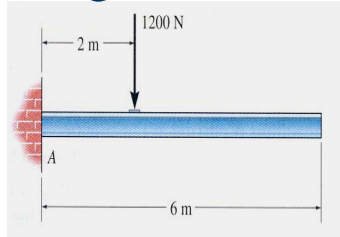

Idealized model

Free body diagram

1. Draw an outlined shape. Imagine the body to be isolated or cut “free” from its constraints and draw its outlined shape.
2. Show all the external forces and couple moments. These typically include: a) applied loads, b) support reactions, and, c) the weight of the body.

ENES110 ©Asst.Kaf_SPO7

Procedure for Drawing a Free Body Diagram (Section 5.2) (cont'd)

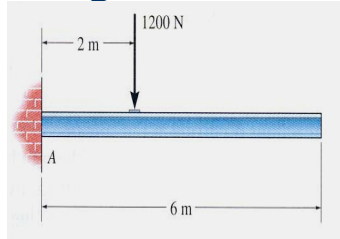

Idealized model

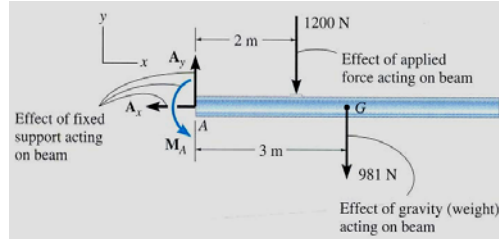

Free body diagram

3. Label loads and dimensions: All known forces and couple moments should be labeled with their magnitudes and directions. For the unknown forces and couple moments, use letters like A_x , A_y , M_A , etc.. Indicate any necessary dimensions.

ENES110 ©Asst.Kat_SPO7

Support Reactions in 2-D

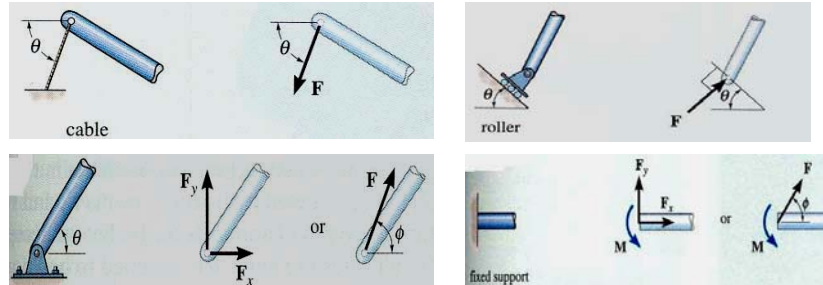

A few examples are shown above. Other support reactions are given in your textbook (in Table 5-1).

As a general rule, if a support prevents translation of a body in a given direction, then a force is developed on the body in the opposite direction. Similarly, if rotation is prevented, a couple moment is exerted on the body.

ENES110 ©Asst.Kat_SPO7

Example

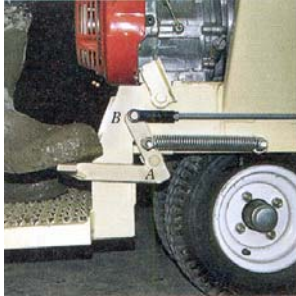

Given: An operator applies 20 lb to the foot pedal. A spring with $k = 20 \text{ lb/in}$ is stretched 1.5 in.

Draw: A free body diagram of the foot pedal.

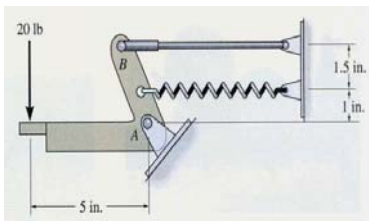

The idealized model

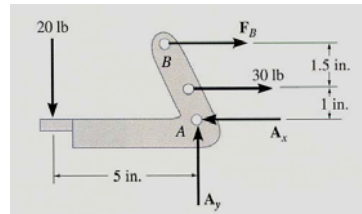

The free body diagram

Concept Quiz

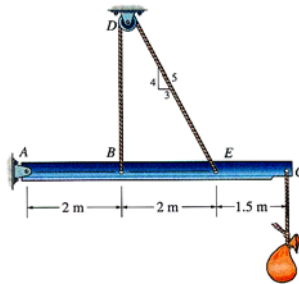

- The beam and the cable (with a frictionless pulley at D) support an 80 kg load at C . In a FBD of only the beam, there are how many unknowns?
 - 2 forces and 1 couple moment
 - 3 forces and 1 couple moment
 - 3 forces
 - 4 forces

Concept Quiz (cont'd)

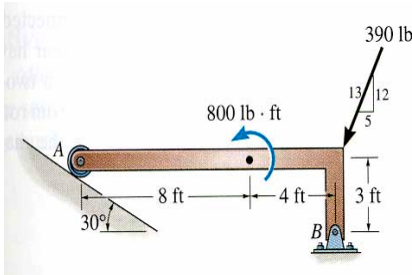

2. If the directions of the force and the couple moments are reversed, then what will happen to the beam?
- A) The beam will lift from A.
 - B) The beam will lift at B.
 - C) The beam will be restrained.
 - D) The beam will break.

ENES110 ©AsstKat_SP07

Example 1

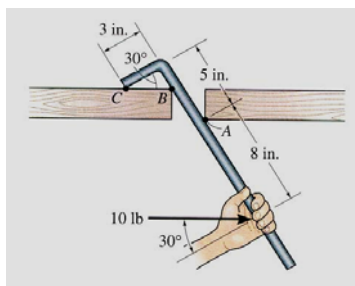

Problem 5-9

Draw a FBD of the bar, which has smooth points of contact at A, B, and C.

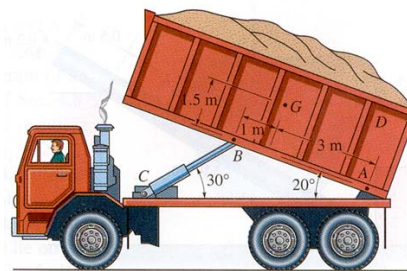

Draw a FBD of the 5000 lb dumpster (D). It is supported by a pin at A and the hydraulic cylinder BC (treat as a short link).

ENES110 ©AsstKat_SP07

Example 1 (cont'd)

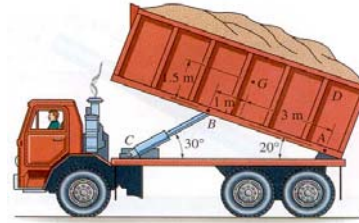
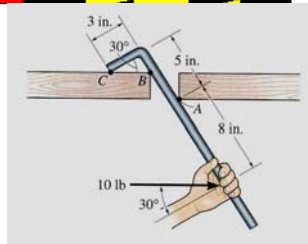

Problem 5-9

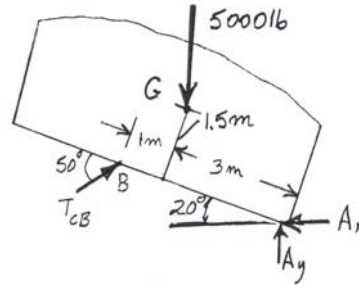
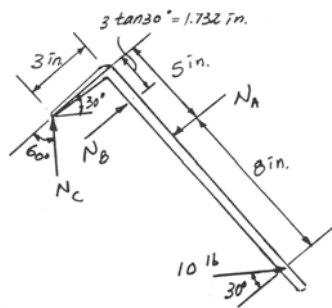

ENES110 ©AsstProf_SPO7

Attention Quiz

1. Internal forces are not shown on a free body diagram because the internal forces are _____. (Choose the most appropriate answer.)

- A) equal to zero
- B) equal and opposite and they do not affect the calculations
- C) negligibly small
- D) not important

2. How many unknown support reactions are there in this problem?

- A) 2 forces and 2 couple moments
- B) 1 force and 2 couple moments
- C) 3 forces
- D) 3 forces and 1 couple moment

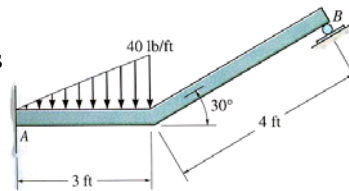

ENES110 ©AsstProf_SPO7